

Water Swivel Spout

Manufacturers Information | PN1173

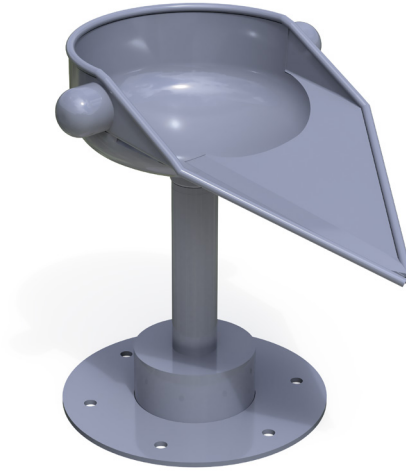

Material Specifications

Spout and Base	Stainless Steel
Fixings	Stainless Steel
Bush	HDPE

Equipment Specifications

Free Height of Fall	Not required
Fall Zone Size	Not required
Activity Space Recomm.	2300mm Diameter
Highest Point	354mm

Other Required Information

Spare Parts	Available to order
Largest Part	Item
Heaviest Part	Item: 0-20kg One Person Lift

Standards

AS 4685 2021 Series

Applications

Age Group	3 years +
Supervision Level	Young children should be supervised and inappropriate activities discouraged
Playspaces	Public parks, schools, early childhood centres commercial play areas
Environment	Shade preferred for user comfort and protection.
Vandalism Resistance	Low susceptibility

Product Dimensions

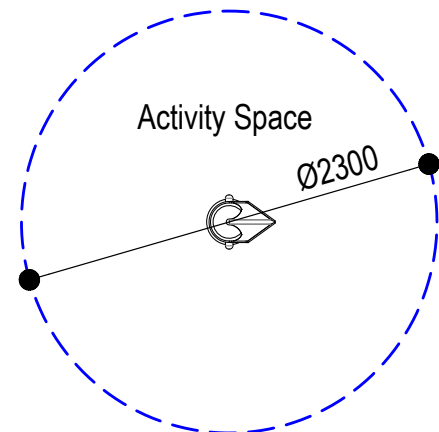
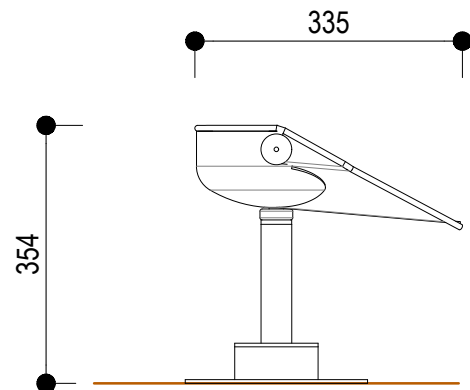

Water Swivel Spout

Manufacturers Information | PN1173

Installation

Footing quantities and depths

From ground level

Item	Qty	Hole Diameter	Hole Depth
n/a			

Note:

This product is designed for no softfall.
Bolt down directly to deck or concrete slab.

Bolt to Deck or Slab
6 x Ø12mm Holes
On Ø200mm PCD

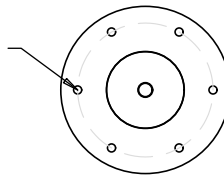

Section A-A

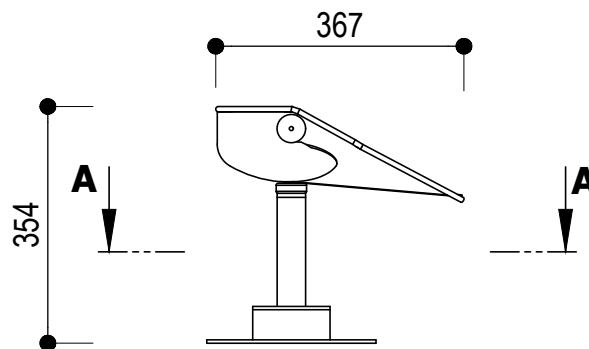

Inspection Notes

All inspections and maintenance to be carried out by competent people with the appropriate knowledge, experience and authority.

Inspection Frequencies

These are a guide only - local risk factors such as heavy usage, nearness to coast, and vandalism patterns need to be taken into account.

Routine Visual Inspection - Daily

Check for breakages, loose fittings and debris. Where safety issues are identified, quarantine until repaired.

Operational Inspection - Quarterly

RVI plus:-
Check for wear in moving parts e.g. bearings, chains and links.
Check security of fixings.

Comprehensive Inspection - Annually

OI plus :-
Check for structural rigidity and degradation e.g. corrosion, decay etc.
Where possible, remove undersurfacing to examine condition of supports and footings.

Maintenance - Annual

In areas of high exposure to sun, wind and rain more frequent treatments may be necessary.

Note: Ensure all replacement parts conform with manufacturers original specifications

Note: In heavy use environment, more frequent inspection regime recommended

Note: Quarantine equipment during installation, inspection & maintenance