

Water Pump Classic

Manufacturers Information | PN444



Material Specifications

Pump	Stainless Steel
Handle	Cast Aluminium
Reservoir	Stainless Steel
Pump Pick Up	PVC
Fixings	Stainless Steel
Bearings	Bronze

Equipment Specifications

Free Height of Fall	Not required
Fall Zone Size	Not required
Activity Space Recomm.	Allow 1m around equipment
Highest Point	Handle 960mm

Other Required Information

Can be connected to mains water or gravity fed from a water tank provided there is sufficient pressure.
Connection point is to the reservoir to a standard 15mm threaded plumbing fitting.

Spare Parts	Available to order
Heaviest Part	21 - 40kg Two Person Lift

Standards

AS 4685 2021 Series

Applications

Age Group	3 years +
Supervision Level	Young children should be supervised and inappropriate activities discouraged
Playspaces	Public parks, schools, early childhood centres commercial play areas
Environment	Shade preferred for user comfort and protection. Salt air environments may reduce life of steel.
Vandalism Resistance	Low susceptibility

Product Dimensions

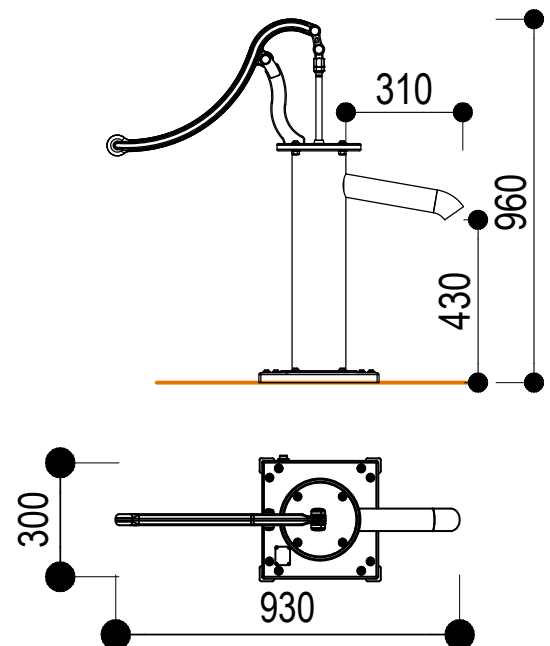

Water Pump Classic

Manufacturers Information | PN444

Installation

Footing quantities and depths

From ground level

Item	Qty	Hole Diameter	Hole Depth
Pump	1	500mm	250mm

Note:

This product is designed for 50mm softfall. Check the proposed on site softfall depth. If it is not 50mm, please adjust depths of post holes accordingly, to achieve correct overall subsurface depth. This will maintain correct height of equipment above undersurface level.

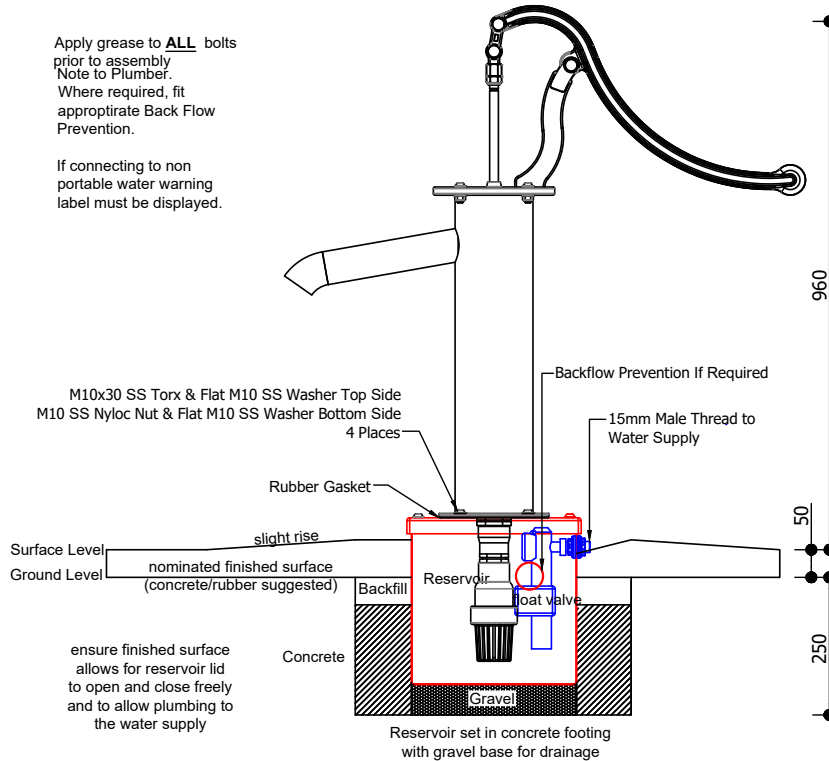

Inspection Notes

All inspections and maintenance to be carried out by competent people with the appropriate knowledge, experience and authority.

Inspection Frequencies

These are a guide only - local risk factors such as heavy usage, nearness to coast, and vandalism patterns need to be taken into account.

Routine Visual Inspection - Daily

Check for breakages, loose fittings and debris. Where safety issues are identified, quarantine until repaired.

Operational Inspection - Quarterly

RVI plus:-
Check for wear in moving parts e.g. bearings, chains and links.
Check security of fixings.

Comprehensive Inspection - Annually

OI plus :-
Check for structural rigidity and degradation e.g. corrosion, decay etc.
Where possible, remove undersurfacing to examine condition of supports and footings.

Maintenance - Annual

In areas of high exposure to sun, wind and rain more frequent treatments may be necessary.

Note: Ensure all replacement parts conform with manufacturers original specifications

Note: In heavy use environment, more frequent inspection regime recommended

Note: Quarantine equipment during installation, inspection & maintenance